

SPECIFICATIONS

LENGTH: 28"
WIDTH: 28"
HEIGHT: 42"
WEIGHT: 480 LBS
HYDRAULICS REQUIRED: 25GPM @ 2850PSI

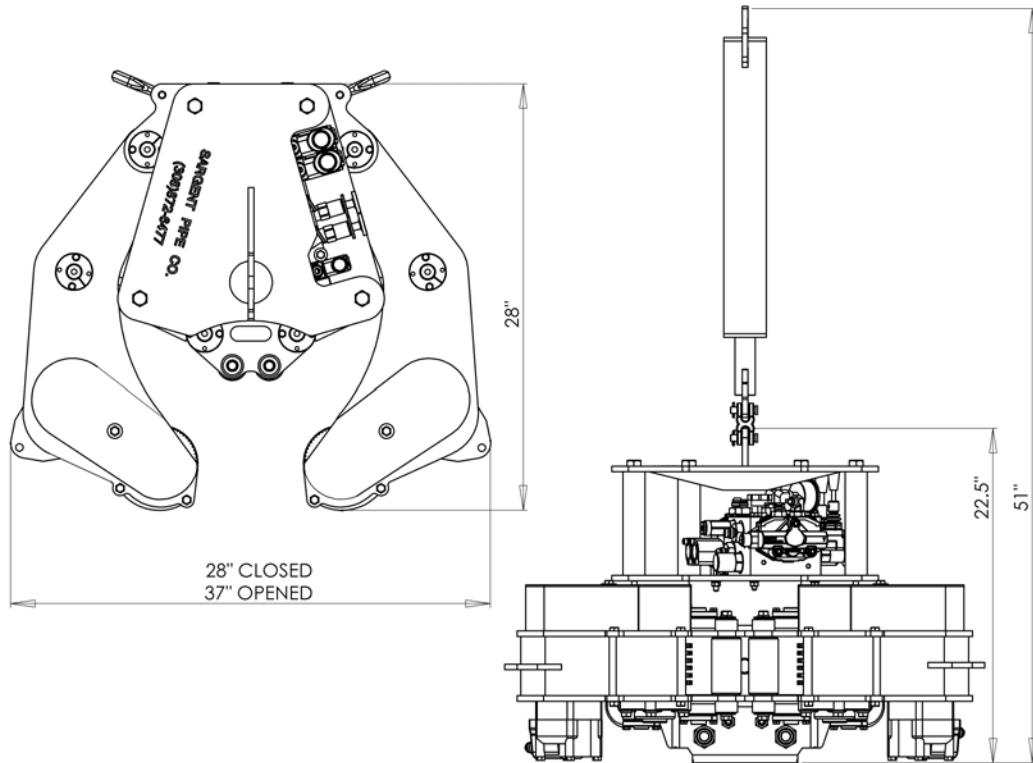

THEORETICAL TORQUE
3000PSI @ 25 GPM
10" PIPE 2295 FOOT POUND OF TORQUE @ 90 RPM
TORQUE CHART ON NEXT PAGE